

Chapter 3

Polynomial and Rational Functions

Review sections as needed from Chapter 0, Basic Techniques, page 8.

Refer to page 187 for an example of the work required on paper for all graded homework unless directed otherwise by your instructor.

3.1 Polynomial Functions and Their Graphs

Exercises Do the following graphs on your calculator.

- (a) Graph $f(x) = (x + 1)(x - 1)(x - 3)$ and find the local extrema values of the function to the nearest tenth.

(b) Using your results for $f(x)$ and part (a), find the local extrema values of $g(x) = (x + 1)(x - 1)(x - 3) + 2$ algebraically.

(c) Now graph $g(x) = (x + 1)(x - 1)(x - 3) + 2$ and verify your answers from part (b) by finding the local extrema values on the graph.
- (a) Graph $P(x) = (x - 1.2)(x - 2.1)(x + 1.7)$ and find all local extrema values of $P(x)$ to the nearest tenth.

(b) Using your results for $P(x)$ and part (a), find the local extrema values of $R(x) = (x - 1.2)(x - 2.1)(x + 1.7) + 20$ algebraically.

(c) Now graph $R(x) = (x - 1.2)(x - 2.1)(x + 1.7) + 20$ and verify your answers from part (b) by finding the local extrema values of $R(x)$ on the calculator graph.

3. Graph $y_1 = x^4$, $y_2 = x^4 - 4x$, $y_3 = x^4 - 4x^2 + 1$, $y_4 = x^4 + 2x^3 - x^2 - x + 2$ on separate graphs and sketch them on paper.

How many turning points do you see in each function?

What can you say about the number of turning points based on the degree of the function?

How many x -intercepts does each function have?

Thinking about all the different versions we could have of a degree 4 function, what can you say about the number of x -intercepts for a function of degree 4?

4. Graph $y_1 = x^3$, $y_2 = x^3 - 3x$, $y_3 = x^3 - 3x + 2$ on separate graphs and sketch them on paper.

How many turning points do you see in each graph?

What can you say about the number of turning points based on the degree of the function?

How many x -intercepts does each function have?

Thinking about all the different versions we could have of a degree 3 function, what can you say about the number of x -intercepts for a function of degree 3?

5. An open box is to be constructed from a piece of cardboard 15.8 inches by 42.6 inches by cutting squares of side length x from each corner and folding up the remaining sides. Round answers to one decimal place.

a) Express the volume V of the box as a function of x , and find the domain.

b) Graph $V(x)$.

c) Find the maximum volume.

d) What size square cutout produces the maximum volume?

e) For what values of x is the volume larger than 1000 cubic inches?

6. An open box is to be constructed from a piece of cardboard 10.5 inches by 22.7 inches by cutting squares of side length x from each corner and folding up the remaining sides. Round answers to two decimal places.

a) Express the volume V of the box as a function of x , and find the domain.

b) Graph $V(x)$.

c) Find the maximum volume.

d) What size square cutout produces the maximum volume?

e) For what values of x is the volume larger than 150 cubic inches?

3.2 Dividing Polynomials

Review section 0.3.1 (Rational Functions, page 21).

Refer to page 187 for an example of the work required on paper for all graded homework unless directed otherwise by your instructor.

Exercises

- (a) Divide $\frac{x^6 + x^4 + x^2 + 1}{x^2 + 1}$ algebraically.

(b) Graph $y = \frac{x^6 + x^4 + x^2 + 1}{x^2 + 1}$ and your algebraic answer on the same coordinate system to verify they are equivalent.
- (a) Divide $\frac{x^6 + x^5 - x^4 + 2x^3 + 3x^2 - x - 1}{x^2 + x - 1}$ algebraically.

(b) Graph $y = \frac{x^6 + x^5 - x^4 + 2x^3 + 3x^2 - x - 1}{x^2 + x - 1}$ and your algebraic answer on the same coordinate system to verify they are equivalent.
- (a) Use the Factor Theorem to show that $x - 2$ is a factor of $P(x) = x^3 + 2x^2 - 3x - 10$.

(b) Graph $P(x) = x^3 + 2x^2 - 3x - 10$.
What on the graph indicates that $x - 2$ is a factor of $P(x)$?

(c) Graph $Q(x) = x^3 - 2x^2 + 3x - 5$. Is $x - 2$ a factor of $Q(x)$?
- (a) Graph $P(x) = x^4 + 4.8x^3 - 3.47x^2 - 15.942x + 12.1072$.

(b) Use the graph to decide if $x - 0.8$ is a factor of $P(x)$.
Explain how you made your decision.

(c) Is $x - 1.5$ a factor of $Q(x) = x^4 - 1.3x^3 - 3.61x^2 + 3.013x + 2.184$?
Explain how you made your decision (similar to parts (a) and (b)).

5. Specify a polynomial function $f(x)$ that might have the graph shown with a window of $[-1, 4]$ by $[-3, 3]$. (More than one answer is possible. Leave function in factored form.)

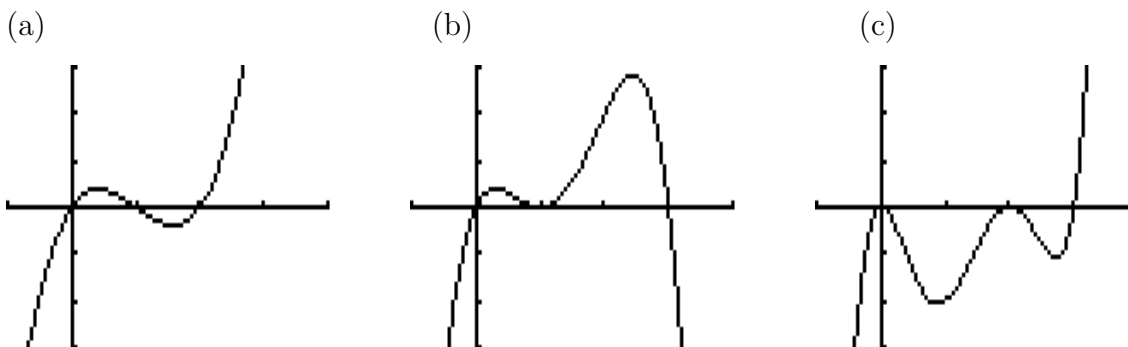

6. Specify a polynomial function $f(x)$ that might have the graph shown. (More than one answer is possible. Leave function in factored form.)

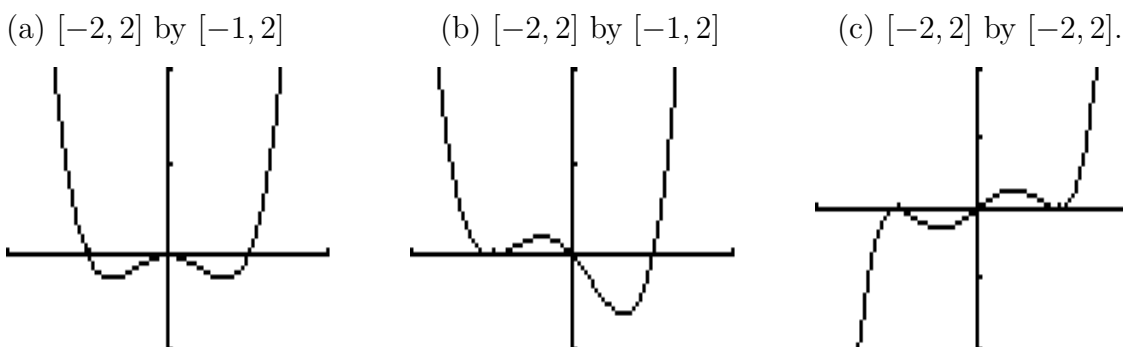

7. Given $f(x) = x^2 - bx + 5$, do the following.

(a) Algebraically, find the value of b so that $x + 2$ is a factor of $f(x)$.
(Hint: Use the factor theorem and the remainder theorem.)

(b) Rewrite $f(x)$ using your value of b found in part (a). On your calculator, graph $f(x)$ and verify that $x + 2$ is a factor of $f(x)$.

8. Given $f(x) = x^4 - bx^3 + bx^2 + 1$, do the following.

(a) Algebraically, find the value of b so that $x + 2$ is a factor of $f(x)$.
(Hint: Use the factor theorem and the remainder theorem.)

(b) Rewrite $f(x)$ using your value of b found in part (a). On your calculator, graph $f(x)$ and verify that $x + 2$ is a factor of $f(x)$.

3.3 Real Zeros of Polynomials

Refer to page 187 for an example of the work required on paper for all graded homework unless directed otherwise by your instructor.

Exercises

1. Use the graph shown of $f(x)$ on $[-4, 3]$ by $[-9, 5]$ to help find all the zeros of $f(x) = x^4 + x^3 - 6x^2 - 2x + 4$. Determine the possible *integer* zeros by looking at the graph. Verify your choices *are* actually zeros by using synthetic division. Then use these integer zeros to help find the others.

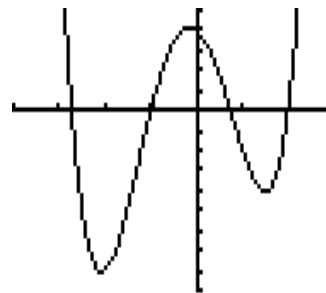

Express all zeros by using exact values, not the decimal approximation.

2. Find all the zeros of $f(x) = x^4 + 4x^3 + x^2 - 4x - 2$ by graphing $f(x)$ and using the graph to determine possible integer zeros. Verify this information and use it to help find the other zeros. Express all zeros by using exact values, not the decimal approximation.

3. A rectangular box is to be made from a piece of cardboard 5 inches by 8 inches by cutting out squares of side length x from each corner, and folding up the remaining sides. If the volume of the finished open box is to be 14 cubic inches, what is the size of the square cutout, rounded to two decimal places?

4. Dalton has a solid cube of length x on each side. He cuts off a slice 1 inch thick from *one* side. The volume of the remaining cube is now 294 cubic inches. What is the length of the sides of the *original* cube?

Show the equation you need to solve, solve it by graphing, and state your answer in words.

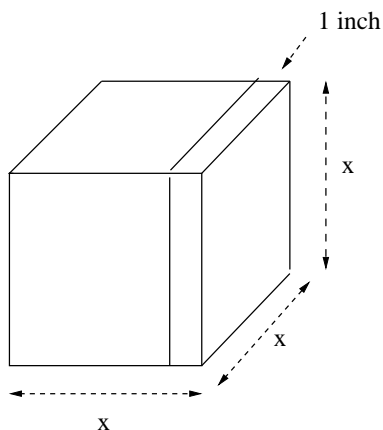

3.4 Complex Numbers

Recall that when solving a quadratic equation, $ax^2 + bx + c = 0$, the discriminant $b^2 - 4ac$ indicates the number and type of solutions to the equation. When the discriminant is negative, there are no real solutions, but we have two “nonreal complex” solutions. Real solutions are also x -intercepts. Nonreal complex solutions do not intersect the x -axis.

Refer to page 187 for an example of the work required on paper for all graded homework unless directed otherwise by your instructor.

Exercises

1. Find all solutions of $3x^2 - 2x + 4 = 0$ algebraically, expressing nonreal complex numbers in standard form $a + bi$. Then graph the formula to verify there are no real solutions.
2. Find all solutions of $-2x^2 + 8x - 10 = 0$ algebraically, expressing nonreal complex numbers in standard form $a + bi$. Then graph the formula to verify there are no real solutions.
3. How many and what kind of solutions does each quadratic equation $f(x) = 0$ have, based on the graph shown? Specify whether the discriminant is positive, negative, or zero for each, and explain your reasoning.

(a)

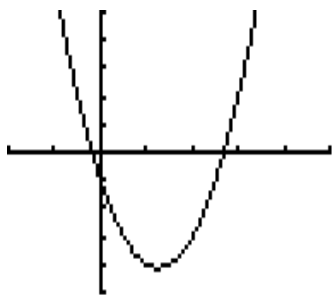

(b)

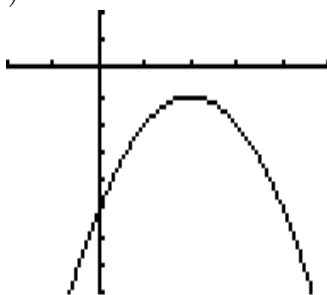

(c)

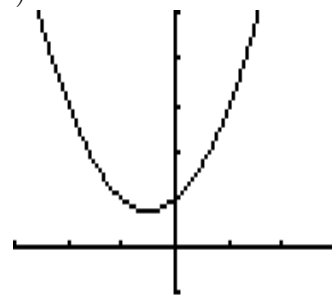

4. How many and what kind of solutions does each quadratic equation $f(x) = 0$ have, based on the graph shown? Specify whether the discriminant is positive, negative, or zero for each, and explain your reasoning.

(a)

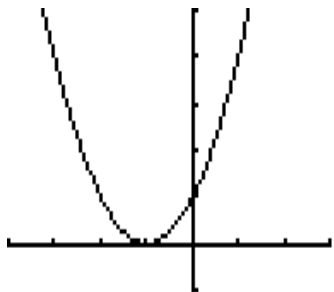

(b)

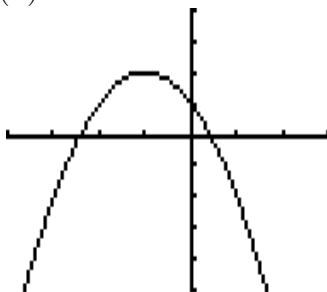

(c)

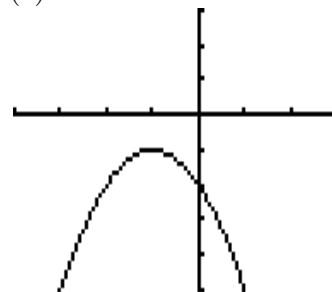

3.5 Complex Zeros and the Fundamental Theorem of Algebra

Refer to page 187 for an example of the work required on paper for all graded homework unless directed otherwise by your instructor.

Exercises

Graph each polynomial and determine the number of real and nonreal complex solutions.

1. $P(x) = x^3 - 5x^2 + 2x - 16$

2. $P(x) = x^3 - 5x^2 + 2x + 5$

3. $P(x) = x^4 - x^3 + x^2 - x - 2$

4. $P(x) = x^4 - 8x^2 - 1$

Completely factor $P(x)$. Use the graph shown to help begin the process.

5. $P(x) = x^4 + 4x^3 + 3x^2 - 2x - 6$
[-4, 2] by [-8, 5]

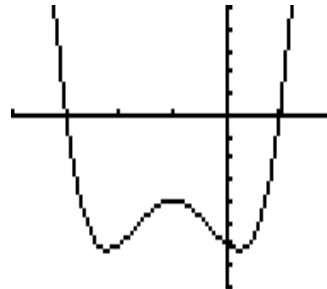

6. $P(x) = x^4 + 2x^3 - 2x^2 - 8x - 8$
[-3, 3] by [-16, 8]

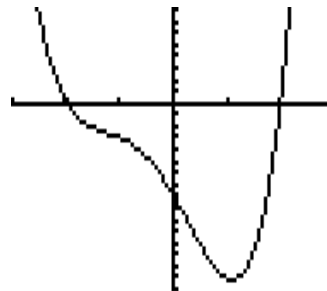

Find all real and nonreal complex zeros of $f(x)$ using exact values.

Graph $f(x)$ to estimate the possible *integer* zeros to start the process, instead of starting with the Rational Zeros Theorem. Show appropriate work for using the graphing calculator.

7. $f(x) = x^4 + 3x^3 - 2x^2 - 10x - 12$

8. $f(x) = x^4 + 2x^3 + x^2 - 2x - 2$

9. $f(x) = x^6 + x^5 - 5x^4 + x^3 - 8x^2 - 2x + 12$

10. $f(x) = -2x^6 - 2x^5 + 12x^4 + 2x^2 + 2x - 12$

11. $f(x) = -2x^6 + 2x^5 + 8x^4 - 4x^3 + 8x^2 - 16x - 32$

12. $f(x) = -2x^7 - 2x^6 + 14x^5 + 14x^4 - 16x^3 - 16x^2 - 32x - 32$

3.6 Rational Functions

Exercises

- Determine
- 1) x -intercepts,
 - 2) vertical and horizontal asymptotes,
 - 3) a possible definition for the function $f(x)$.

Use the graph and window shown, with a scale of 1 unit on the x - and y -axes.

Assume all vertical asymptotes are $x = a$, where a is an integer, and all horizontal asymptotes are $y = b$, where b is an integer.

1. window of $[-2, 5]$ by $[-5, 5]$

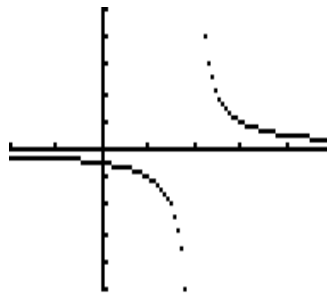

2. window of $[-8, 8]$ by $[-5, 5]$

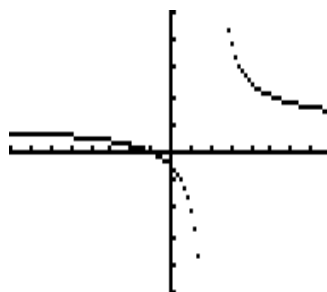

3. window of $[-5, 5]$ by $[-5, 5]$

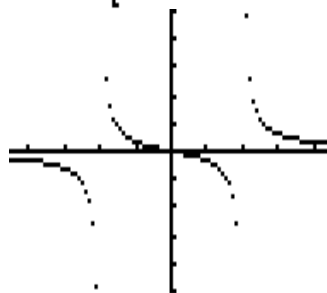

4. window of $[-5, 5]$ by $[-5, 5]$

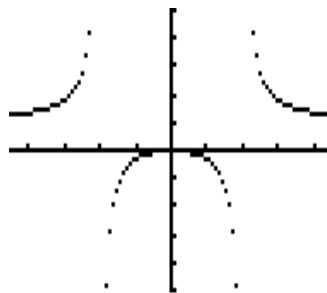

Remember to use *dot* mode for the graphs.

5. Make up a rational function that has these characteristics:

crosses the x -axis at -1 and 2 ,
vertical asymptotes at $x = -3$ and $x = 4$,
horizontal asymptote at $y = 3$.

Graph your function on the calculator. Does the graph match the given information?

6. Make up a rational function that has these characteristics:

crosses the x -axis at -2 and 4 ,
vertical asymptotes are $x = -1$ and $x = 3$,
horizontal asymptote is $y = 2$.

Graph your function on the calculator. Does the graph match the given information?

7. Make up a rational function that has these characteristics:

x -intercept is -1 ,
vertical asymptote is $x = 2$,
no horizontal asymptote

Graph your function on the calculator. Does the graph match the given information?

8. Make up a rational function that has these characteristics:

no x -intercept,
vertical asymptote is $x = 1$,
horizontal asymptote is $y = 0$

Graph your function on the calculator. Does the graph match the given information?